

# Specifications

# Boma

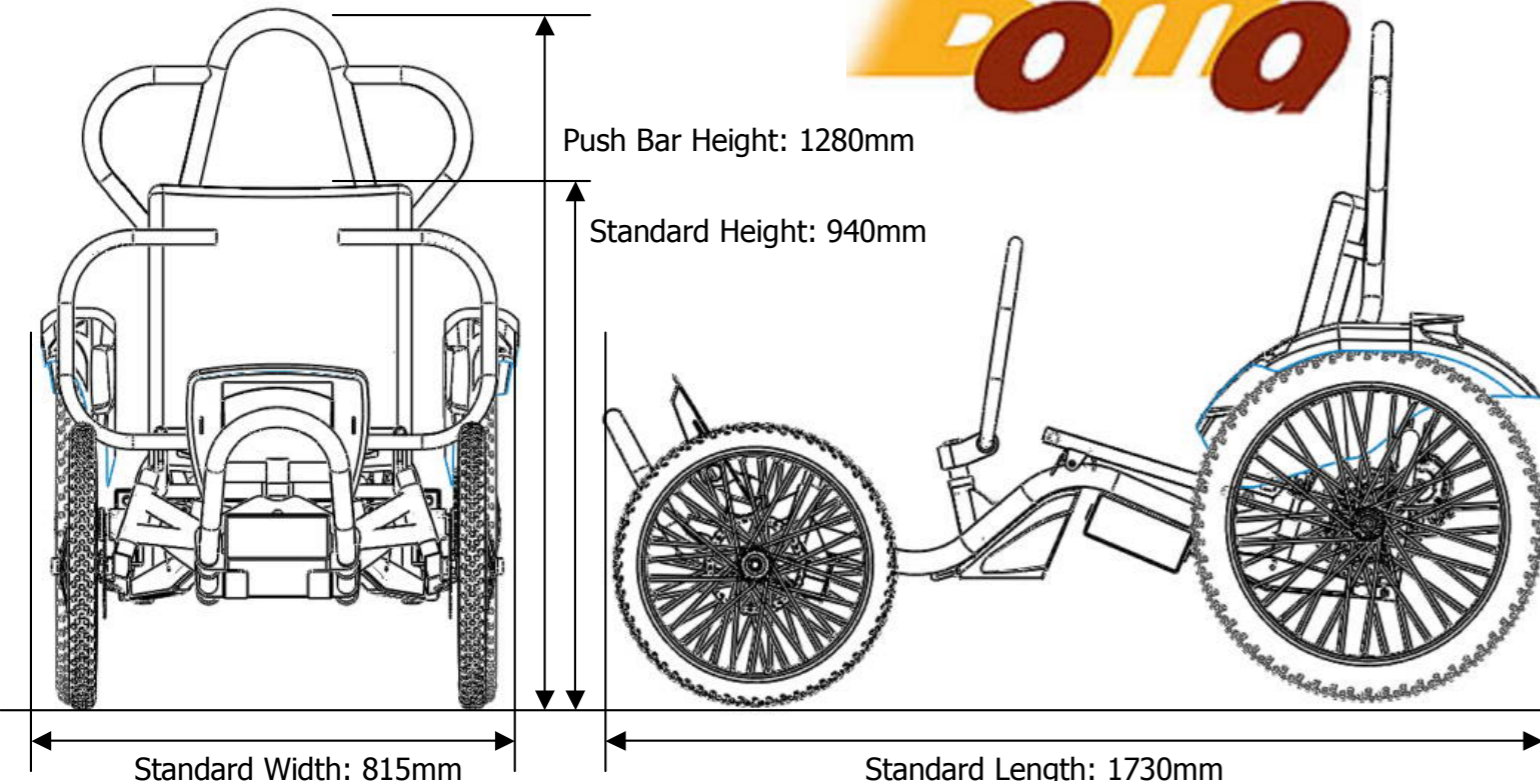

# Boma



### Contact informations :

- STANDARD FEATURES
- ◆ FULL INDEPENDENT ADJUSTABLE FRONT SUSPENSION
  - ◆ QUADYNAMIC™ REAR ADJUSTABLE SUSPENSION SYSTEM
  - ◆ FRONT QUICK RELEASE AXLES
  - ◆ SUPER STRONG FRAME
  - ◆ 24x3" OFF ROAD REAR TYRES
  - ◆ 20x2" OFF ROAD FRONT TYRES
  - ◆ 2 x 24V NiMH BATTERIES
  - ◆ 240V CHARGER
  - ◆ MADE IN THE UK



CE Directive No. 93/42/EEC



All you need to get out there....

## Boma 7 Off Road Wheelchair

On the beach, in the Forest, on the trails, in the mountains or even in the local park; the new Boma 7 can take you there....





## Strong Chassis

The minimal steel tube chassis is incredibly strong, yet flexible increasing off road capability. The frame shape provides clear access for sliding transfers from a wheelchair.

Clip on/off handlebars can be removed clearing any obstacles if you require a hoist assisted access to the Boma.

**"The Boma gives back my freedom; what more could I ask!..."**

Driving controls can be personalised to your individual requirements

# Boma

**"It just makes you want to drive over stuff!"**

An optional seat frame can be specified; perfect for carrying ruck sacks or extra lighting for the more adventurous user.

Powerful, almost silent drive system provides incredible torque for obstacle crossing. Available with optional on demand differential locking.

## Long Range

A range of battery options are available to suit your individual needs.

Super large drum brake hubs and quick release front wheels are provided as standard

## Accessible

Adjustable upholstery is supplied as standard providing a comfortable seating position for long trips.

## Comfortable

Independent coil spring front suspension with adjustable Preloading.

Quaddynamic rear suspension

## Joystick Control Option

Optional joystick control suitable for those with limited hand/arm strength the opportunity to access off road areas in comfort and safety

## Specialist Seating Options

A huge range of specialist seating can be provided according to your specific needs. Please contact us for details...

**"What a feeling! You can't judge the Boma Off Road Wheelchair by what you see in a brochure, on the Internet or on a display stand. Try one!"**



DK2-REM420

